

## AUTOSEALER® 2600 DATA SHEET

EST. 1978

ISO-9001

The **Autosealer® 2600** dispensing system is a touch-activated, all-pneumatic applicator for dispensing high-viscosity Hernon® products onto threaded pipe fittings and nipples. A quick-turn turret offers cavities for 1/16", 1/8", 1/4", 3/8", 1/2", 3/4" and 1" male pipe threads. Once manually actuated, the piston pump expresses a metered amount of material. When the fitting is removed, the pump resets, ready for another cycle. The **Autosealer® 2600** can be fed directly from a 50ml or 250ml tube or an 850 ml cartridge.

- **Autosealer® 2600** Pt# 110020191
- **Autosealer® 2600-850** Pt# 110-060

### Features:

- Applies thread sealants behind leading threads
- Adjust the turret to correct fitting size: 1/8" to 1"
- Pneumatic, touch activated dispense cycle
- Dispenses 50ml, 250ml tubes & 850ml cartridges
- Portable thread sealant dispenser
- Volume knob adjustment

### Specifications:

- Max input air pressure: 100psi
- Operating pressure: 60psi
- Power requirement: N/A
- PPM or Output range: N/A
- Weight: 9lbs
- Range of parts: 1/8" - 1" pipe fittings
- System includes 250ml tube adaptor

### Warranty:

- Standard 1 year from purchase date



850 ml Cartridge Retainer

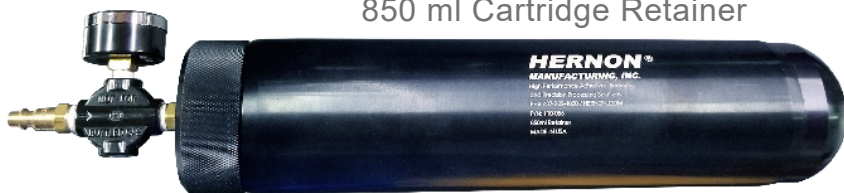

**AUTOSEALER<sup>®</sup> 2600 DATA SHEET**

EST. 1978

ISO-9001

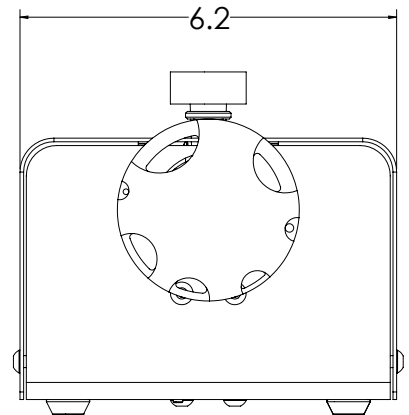
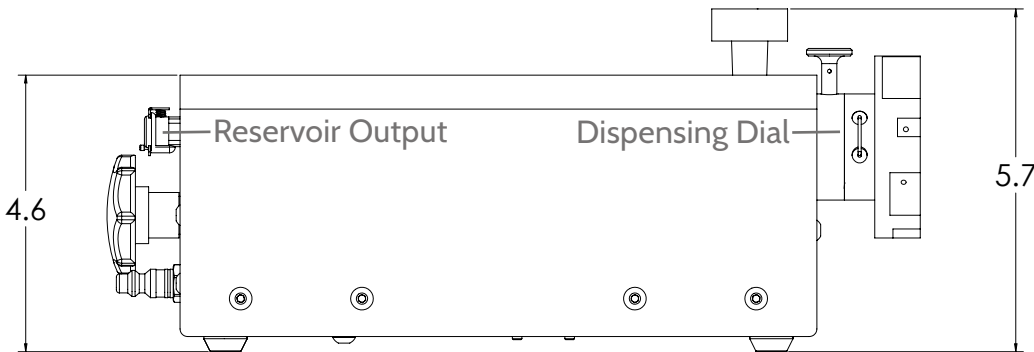
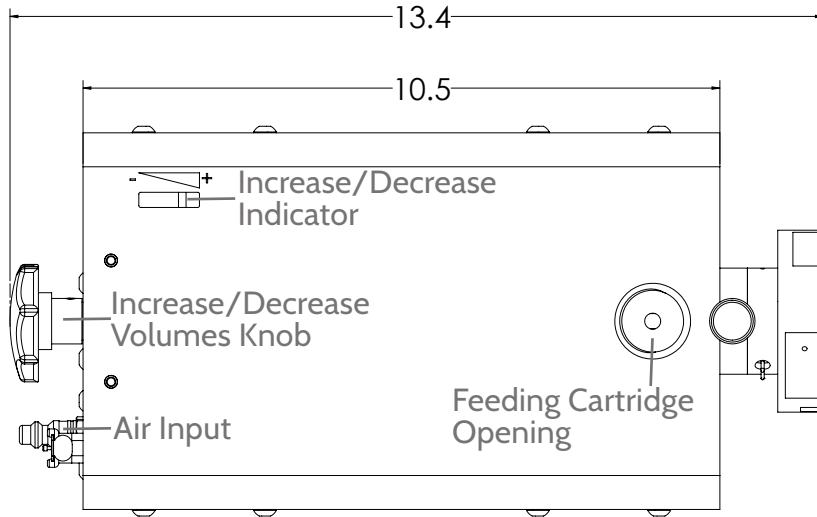

**850ml Cartridge Retainer:**

